

VirtuoSaph® Plus

ENDOSCOPIC VESSEL HARVESTING SYSTEM

Harvesting a New Standard of Care



The handoff.



Be confident what you're passing along is of the highest quality.



What do you need to deliver the optimal conduit? Is it knowing that you controlled hemostasis? Limited thermal spread? Achieved atraumatic dissecting and harvesting? Reduced the risk of CO₂ embolism and intraluminal thrombus? Used a device that is ergonomic and user friendly?

The VirtuoSaph® Plus Endoscopic Vessel Harvesting System delivers all of that with a new standard of care. It integrates key design functions with the knowledge and experience that contribute to successful endoscopic vessel harvesting of the saphenous vein for coronary and peripheral artery bypass grafting.

Here's how the VirtuoSaph Plus System does it...

Controls hemostasis

- Superior sealing and cutting capabilities of the V-cutter
- Precise control of when and where spot cautery is applied with one-of-its-kind integrated spot cautery, activated by the V-cautery switch

Limits thermal spread

- The “cutting triad” – tunnel wall grounding, low wattage, and branch tautness – and a controlled distance between the V-cutter and V-keeper for simultaneous sealing and cutting of branches
- Delivers low targeted energy at the tunnel wall, away from the main conduit

Reduces risk of CO₂ embolism and intraluminal thrombus

- “Open” system distal insufflation with non-occlusive trocar
 - Minimizes the amount of CO₂ needed for tunnel maintenance
 - Minimizes contact and pressure on the vein at the incision site

Several studies support the use of open systems and a non-occlusive trocar¹⁻⁵

- May lower the risk of CO₂ embolism
- May lower the risk of intraluminal clot

Provides space in the tunnel for increased visibility

- Consistently delivers CO₂ at the tip, where it counts

Use of open CO₂ insufflation can lead to dramatic reductions in retained clots. Research has shown the frequent presence of intraluminal clots in vessels harvested endoscopically using a “closed” EVH system.¹⁻³ Two studies showed that CO₂ embolisms are noted about 4% to 17% of the time when using “closed” systems.⁴⁻⁵ Continuous monitoring is suggested to provide early detection and help prevent development of significant CO₂ embolisms.⁵

Atraumatic dissecting and harvesting

- Atraumatic conical dissector tip with centering rings allows the clinician to monitor the location of the dissector cone tip relative to the vein during dissection for consistent and uniform dissection
- PTFE V-Glide surface and flexibility of dissector rod minimize drag and resistance and improve ease of dissection
- The V-keeper gently encapsulates the vein to minimize potential damage to it during cauterization. It is designed to set up the proper branch tautness and work in concert with the V-cutter for optimal sealing and cutting.

Ease of use

- Integrated device minimizes the number of connections and steps, such as the first-of-its-kind integrated bipolar cord
- Unique wiper that immediately improves visibility in one activation
- And the Terumo Method, a proven method for optimal two-pass dissecting and one-pass harvesting

Harvesting a New Standard of Care

Dissector

To dissect the saphenous vein and surrounding branches.



- 1 The **atraumatic conical tip** of the dissector rod offers consistent and uniform dissection.
- 2 **CO₂ delivered at the tip**, consistently provides space in the tunnel for increased visibility.
- 3 The **extended working length** of the dissector rod allows dissection of longer vessel lengths.
- 4 The **PTFE V-glide** surface and flexibility of the dissector rod minimize drag and resistance and make dissection easier.
- 5 The **ergonomic dissector handle** design reduces potential for hand strain.
- 6 **Centering rings** in the dissector cone tip aid in visualization and minimize risk of branch avulsions and vessel perforations.



Trocar

This device is a simple clip-on trocar. The dissector or harvester accesses the saphenous vein by entering the non-occluding trocar through the port. The body of the trocar is inserted into the incision and stays in place with the clip securely placed on the skin allowing fast conversion between procedural steps. It places little or no pressure on the vein at the incision site. Research has shown that clot formation can result if stagnant blood that is not anti-coagulated is allowed to remain within a collapsed saphenous vein.¹

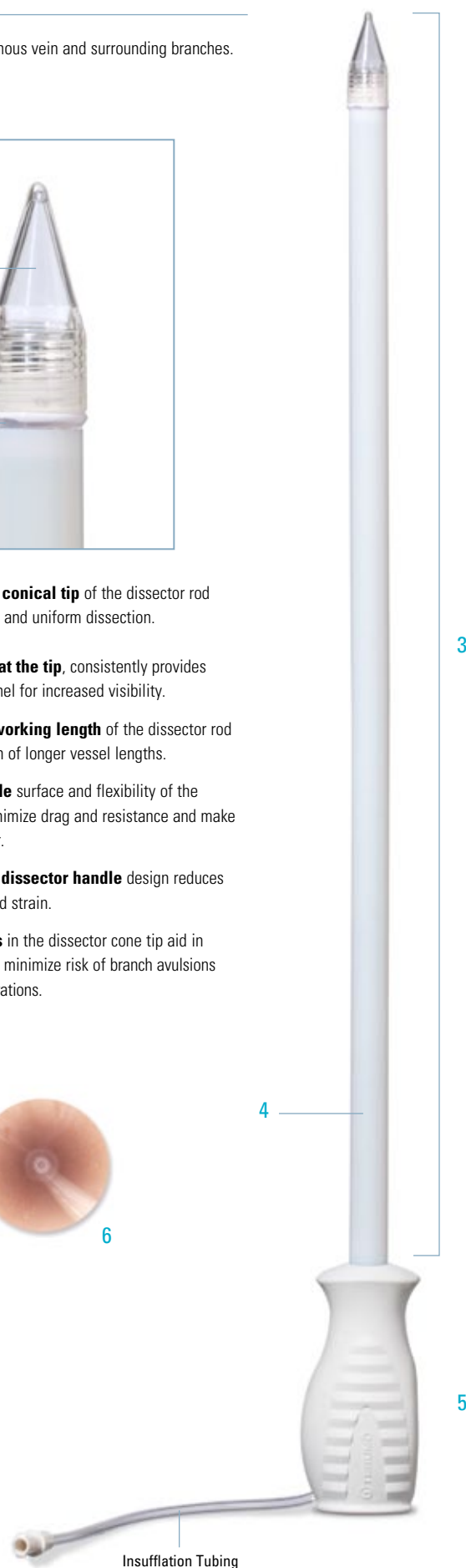

Harvester

To coagulate and cut the branches of the saphenous vein in one easy step.

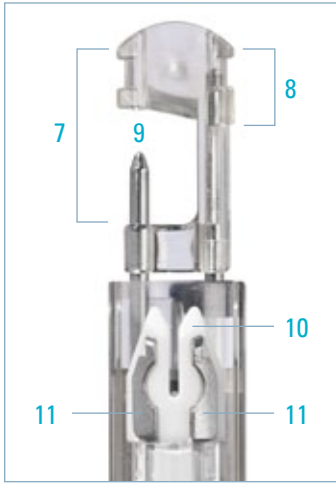

- 7 The **V-keeper** gently encapsulates the vein to minimize potential damage during cauterization. It is designed to set up the proper branch tautness and work in concert with the V-cutter for optimal sealing and cutting.
- 8 The **bilateral notches** anchor the branch to provide optimal tautness during transection.
- 9 The **V-lock** mechanism secures the vein in place during harvesting and transection of branches. It ensures that all branches are coagulated and cut prior to removing the harvester rod from the leg.
- 10 The **V-cutter** is a simple coagulate-and-cut mechanism employing targeted low energy. It provides both functions in one easy step. The safety design of the harvester maintains a controlled distance between the V-keeper and V-cutter to provide consistent branch lengths and help ensure that sealing and cutting take place near the tunnel wall and not near the conduit. The V-cutter automatically responds to changes in tissue resistance as the branch is first sealed then cut.
- 11 The **V-cutter** can also deliver spot cautery to the tunnel wall for added hemostasis control.
- 12 The **V-cautery switch** gives precise control of when and where spot cautery is applied.
- 13 The first-of-its-kind **integrated bipolar cord** improves the efficiency of surgical preparation by reducing the number of steps and connections for harvesting.

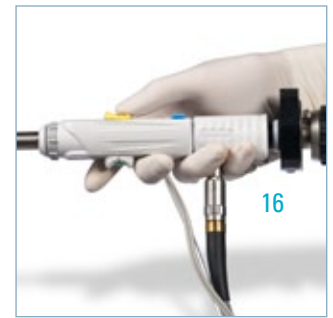

- 14 **CO₂ delivered at the tip** consistently provides space in the tunnel for increased visibility. Use of open CO₂ insufflation can lead to dramatic reductions in retained clots.¹
- 15 The **unique wiper** located on the harvester rod clears and cleans the endoscope lens of fat or blood to improve procedural visibility without adding fluid in the cavity.
- 16 The **ergonomic design of the handles** allows one-handed manipulation of the device for convenience and ease of use.



OLYMPUS

Endoscopic Tower

In the United States, Terumo provides the Olympus hardware components necessary to perform endoscopic vein harvesting including the generator, camera processing unit (CPU), light source, monitor and cart.

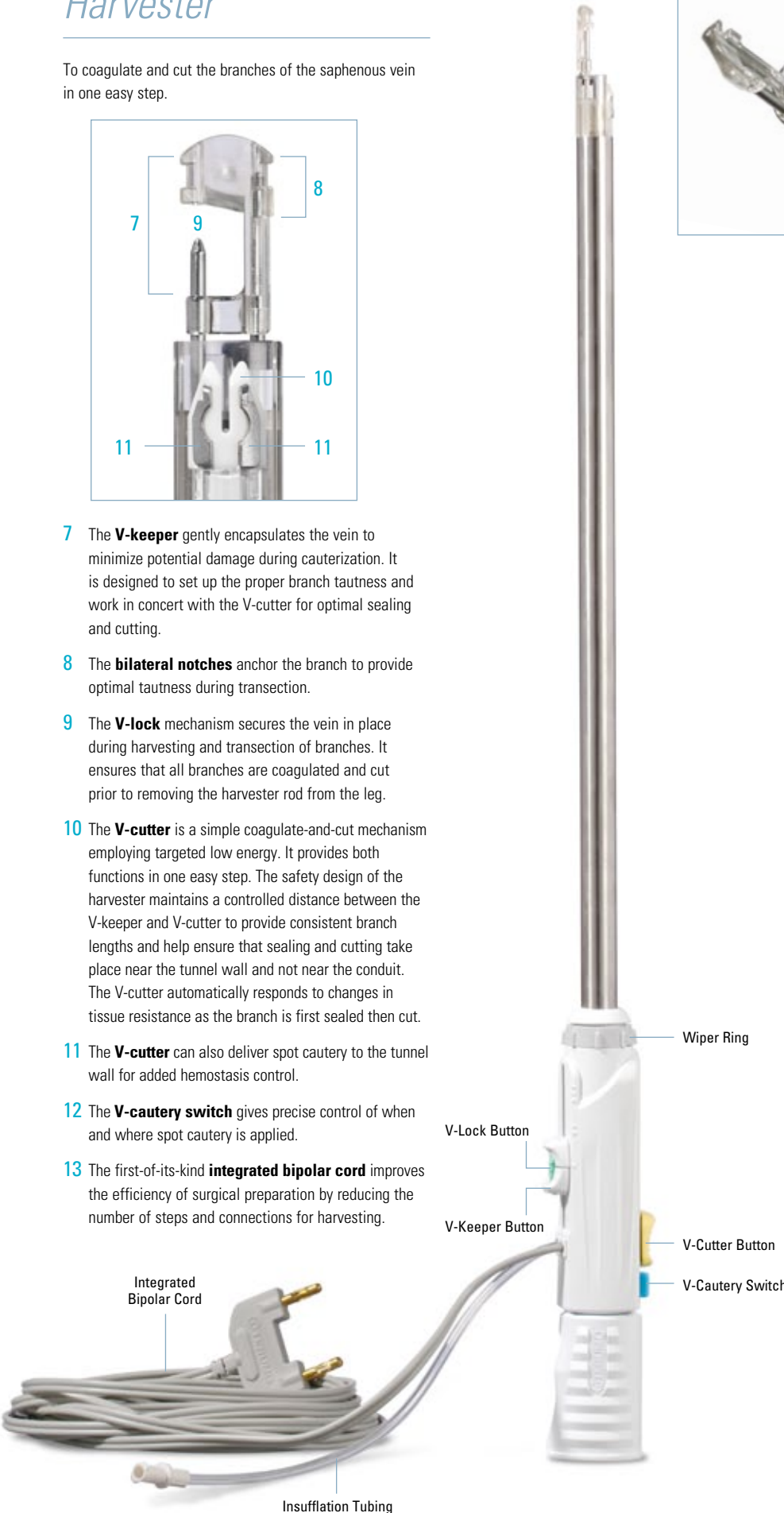

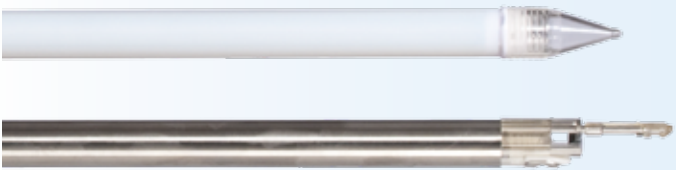

Harvesting a New Standard of Care

Knowledge and Experience

Terumo has conducted extensive research on both design and method, two important factors for consistently successful vein harvesting. The Terumo Method and the design of the Virtuosaph Plus system address all aspects of the vein harvesting procedure – from initial incision to vein removal – to provide an optimal conduit. Each component of the product design has been tested and refined for optimal performance. The Terumo Method was developed with the design in mind by experienced engineers and clinicians to elevate standards for patient safety, conduit quality, and ergonomics.

Continuing Support

Terumo supports its products and the clinicians who use them with a commitment to service before, during and after the evaluation. Comprehensive training is available including advanced techniques and access to a clinical support team with more than 100 years combined vein harvesting experience. Centers of Excellence are also available to bring together clinicians interested in evaluating Terumo's endoscopic vein harvesting products and experienced clinicians already successfully using them. The Centers facilitate the learning of techniques and procedures that can improve patient outcomes through case observations, discussions with experienced clinicians, and product demonstrations.

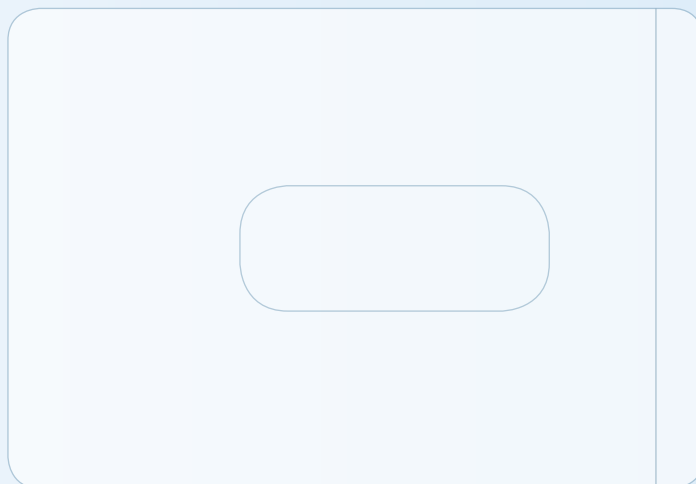



VirtuoSaph® Plus

ENDOSCOPIC VESSEL HARVESTING SYSTEM



Harvesting a New
Standard of Care



Ordering Information	Product Code	Units/Case
Disposable Products		
VirtuoSaph Plus Endoscopic Vessel Harvesting System, sterile, (includes dissector, harvester and trocar)	VSP550	5
Trocar, sterile (for spare)	MCTRC550S	10
Endoscope		
5.5 mm Endoscope	MCENDO550	1
Generator		
Generator*	UES-40	1
Sterilization Trays		
Endoscope Only Tray	811497	1
All Components Tray	811496	1

*Manufactured by Olympus Corporation, Tokyo, Japan. Available in the United States only.

For more information on tower components and generator compatibility, please contact your local Terumo sales representative or call Customer Service at (888) 758-8000.

www.terumo-cvs.com/vsplus

FOOTNOTES

- 1 Brown et al. Strategies to reduce intraluminal clot formation in endoscopically harvested saphenous veins. *J Thorac Cardiovasc Surg* 2007;134:1259-1265.
- 2 Burris et al. Incidence of residual clot strands in saphenous vein grafts after endoscopic harvest. *Innovations: Technology & Techniques in Cardiothorac & Vasc Surg* 2006;1(6):323-327.
- 3 Burris et al. Catheter-based infrared light scanner as a tool to assess conduit quality in coronary artery bypass surgery. *J Thorac Cardiovasc Surg* 2007;133:419-42.
- 4 Chiu et al. Reduction of carbon dioxide embolism for endoscopic saphenous vein harvesting. *Ann Thorac Surg* 2006;81:1697-1699.
- 5 Lin et al. Carbon dioxide embolism during endoscopic saphenous vein harvesting in coronary artery bypass surgery. *J Thorac Cardiovasc Surg* 2003;126:2011-2015.



Manufactured by:
 TERUMO CARDIOVASCULAR
 SYSTEMS CORPORATION
 6200 Jackson Road
 Ann Arbor, Michigan
 48103-9300
 USA
 800 521 2818
 734 663 4145
 734 663 7981 fax

EC REP
 TERUMO EUROPE N.V.
 Interleuvenlaan 40
 B-3001 Leuven
 Belgium
 32 16 38 12 11
 32 16 40 02 49 fax

TERUMO CORPORATION
 44-1, 2-chome, Hatagaya,
 Shibuya-Ku
 Tokyo 151-0072
 Japan
 81 333 74 8111
 81 333 74 8399 fax

www.terumo-cvs.com

Terumo® and VirtuoSaph® are registered trademarks of Terumo Corporation.
 OLYMPUS™ is a trademark of Olympus Corporation.
 Printed in the U.S.A. © 2010 Terumo Cardiovascular Systems Corporation 820588